



2802 WHITE HORSE ROAD
GREENVILLE, SOUTH CAROLINA 29611
(864) 605-5000

PROJECT METROWALL TO FACTORY TOPPED DT
CORBEL/ADD-ON CORBEL

JOB NO.
STD

DATE
01/04/05

DWN. BY
STAFF

DATE
11/16/2010

CHK. BY
HAG

SHEET
D0510

COORDINATOR NOTE:
STANDARD STEEL SHIM PLATES SHALL BE ORDERED & SUPPLIED WITH THE ERECTION MATERIALS FOR USE WITH THE EP560'S AS FOLLOWS ON FACTORY TOPPED DT'S:
EP533 - $\frac{3}{8}$ " X 6" X 6" AT 25%
EP534 - $\frac{1}{4}$ " X 6" X 6" AT 25%
CHANGE TO PLASTIC IF GALV. MAT'L NON-SLIP

DRAFTER NOTE:
IF VERTICAL METROWALL,
CONNECTION AT BOTH STEMS

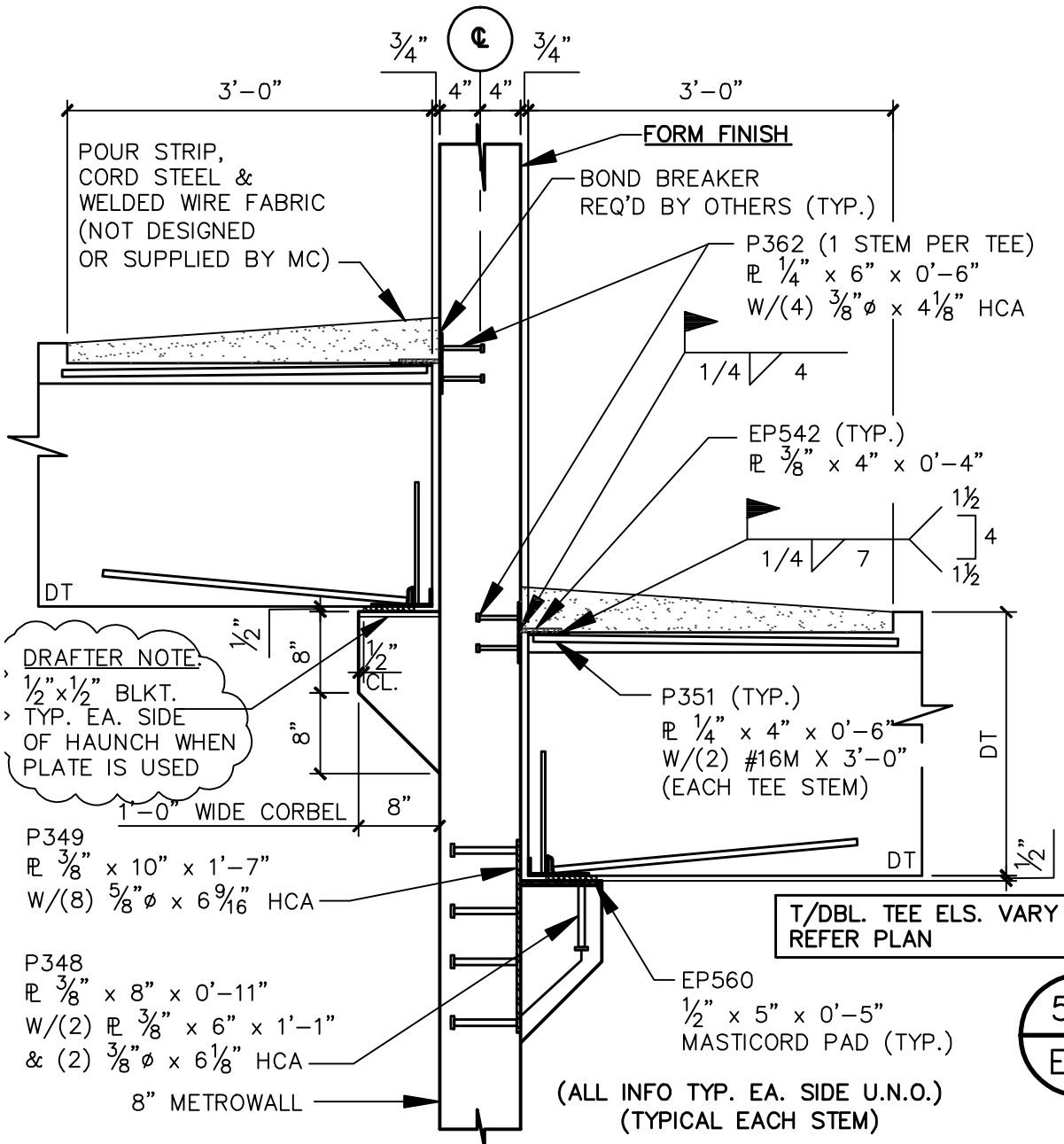

DRAFTER NOTE:
 $\frac{1}{2}$ " x $\frac{1}{2}$ " BLKT.
TYP. EA. SIDE
OF HAUNCH WHEN
PLATE IS USED

T/DBL. TEE ELS. VARY
REFER PLAN

510
E00

(ALL INFO TYP. EA. SIDE U.N.O.)
(TYPICAL EACH STEM)

MPC_8 1/2" x 11" Detail