



2902 WHITE HORSE ROAD  
GREENVILLE, SOUTH CAROLINA 29611  
(864) 605-5000

PROJECT PANEL TO CIP CONCRETE CELL  
OR PRECAST CELL

JOB NO.  
STD

DATE  
01/04/05

DWN. BY  
STAFF

DATE  
11/16/2010

CHK. BY  
HAG

SHEET  
D1500

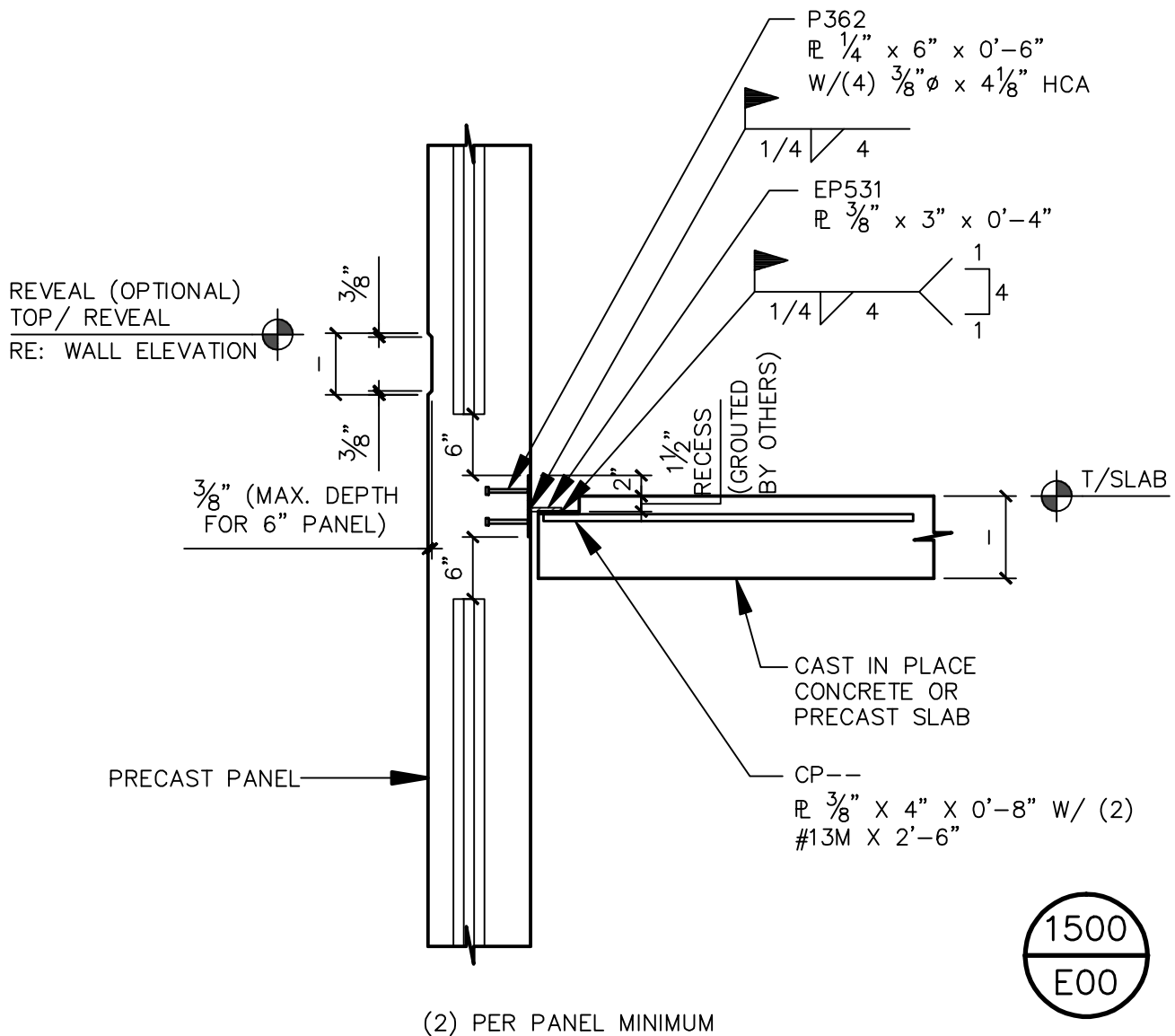

MPC\_8 1/2" x 11" Detail